

SPECIFICATION FOR APPROVAL

CUSTOMER : _____

PRODUCT TYPE : SMD LVPECL CXO 5.0*3.2

NOMINAL FREQ. : 156.25MHz

TXC P/N : CBA5600014

REVISION : A3

CUSTOMER P/N : _____

PM / SALES : _____

DATE : _____

CUSTOMER CONFIRMATION : _____
(Singnature)

_____ (Date)

- (1) TXC requires one copy returned with signature and title of authorized individual that signifies acceptance of the attached specifications.
- (2) Orders received and accepted by TXC after return of signed copy of specification will be produced per these specifications.
- (3) Any changes to these specifications must be agreed upon by both parties and new revision of the Product Specification Sheet will be issued.
- (4) Any issuance of purchase order prior to consigning back the Approval page of "Specification Sheets" from customers will be regarded as the agreement on the contents of these specifications.

MSL:Level 1
RoHS Compliant

(for glass crystal only : Pb used in sealing glass material is exempt from EU directive)



SPECIFICATION FOR APPROVAL

PRODUCT TYPE : SMD LVPECL CXO 5.0*3.2

NOMINAL FREQ. : 156.25MHz

TXC P/N : CBA5600014

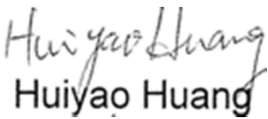
REVISION : A3

PE/RD	QA	MFG
 Oscar Chen	 Huiyao Huang	 Andrew Wei
2018/3/29	2018/3/29	2018/3/29

NOTE:

- (1) The green product standard set by TXC is based upon the international standards. Related information is publicly described on the TXC's Website, and updated regularly. The document is compliant with the latest green product quality system directives at the time.
- (2) Revision "Sx" is for engineering samples only. PE/RD's approval required.
- (3) Revision "Ax" is production ready. PE, QA and MFG's approval required.

MSL:Level 1
RoHS Compliant

(for glass crystal only : Pb used in sealing glass material is exempt from EU directive)



<u>Rev</u>	<u>Revise page</u>	<u>Revise contents</u>	<u>Date</u>	<u>Ref.No.</u>	<u>Reviser</u>
A1	N/A	Initial released (From S1)	2016/8/31	N/A	Oscar Chen
A2	P2	Modify Current Consumption spec.	2016/10/21	EC-PCF-161021-01	Oscar Chen
A3	P2	Modify Frequency Stability & Tr/Tf	2018/3/29	EC-PCF-180328-02	Oscar Chen

ELECTRICAL SPECIFICATIONS

Item	Parameters	Condition	Electrical Specifications			
			MIN	TYP	MAX	UNITS
1	Nominal Frequency (Fo)		156.250000			MHz
2	Oscillation Mode		3rd Overtone			
3	Operating Temperature		-40	-	85	°C
4	Storage Temperature		-55	-	125	°C
5	Frequency Stability	Note 1	-50	-	50	ppm
6	Initial Frequency Tolerance		-12	-	12	PPM
7	Freq. vs Temperature		-25	-	25	PPM
8	Freq. vs Supply Voltage		-2	-	2	PPM
9	Aging	1st. Year at 25°C	-3	-	3	PPM
10	Supply Voltage		2.97	3.30	3.63	V
11	Current Consumption	RL=50Ω to VDD-2V	-	-	50	mA
12	Standby Function	Internal Pull Up	YES			
13	Current Consumption(Standby)	OE=Low	-	-	20	uA
14	Output Type		LVPECL			
15	Output Load		50			Ω
16	Output Voltage High		VDD-1.025	-	VDD-0.88	V
17	Output Voltage Low		VDD-1.81	-	VDD-1.62	V
18	Rise Time	20% ~ 80% Output Swing	-	-	0.4	ns
19	Fall Time	80% ~ 20% Output Swing	-	-	0.4	ns
20	Symmetry		45	50	55	%
21	Start-up Time	To 90% of Final Amplitude	-	-	10	ms
22	Enable Voltage High (Logic 1)	Note 2	0.7VDD	-	-	V
23	Enable Voltage Low (Logic 0)	Note 2	-	-	0.3VDD	V
24	Output Enable Delay Time		-	-	2	ms
25	Output Disable Delay Time		-	-	200	ns
26	Phase Jitter	12k ~ 1MHz	-	-	0.2	ps rms
27	Phase Jitter	12k ~ 20MHz	-	-	0.25	ps rms
28	Phase Noise, fo = 156.25MHz	10kHz offset	-	-	-123	dBc/Hz
		100kHz offset	-	-	-135	dBc/Hz
		1MHz offset	-	-	-150	dBc/Hz
		10MHz offset	-	-	-150	dBc/Hz
29	Aging	first 10 years	-	-	±10	ppm

Note 1 Inclusive of frequency tolerance at 25degC, variation over temperature, supply voltage variation, aging and vibration.

Note 2 Output will be enable if OE is Logic 1 or open ; Output will be disable if OE is Logic 0.

Note 3 The standard testing environment except temperature test is 25±5degC, 40%~70% relative humidity.

TESTING CIRCUIT

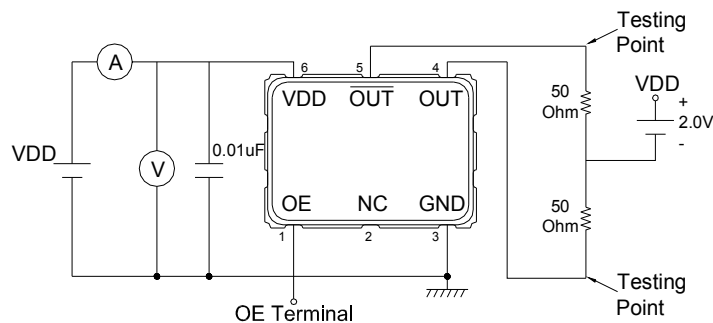

Testing Circuit Note:

- 1) Above testing circuits cover all the specifications except temperature test & Jitter measurement.
- 2) All the testing equipments are 50Ohm terminal.
- 3) OE terminal is open connection except OE function test.

WAVEFORM CONDITONS

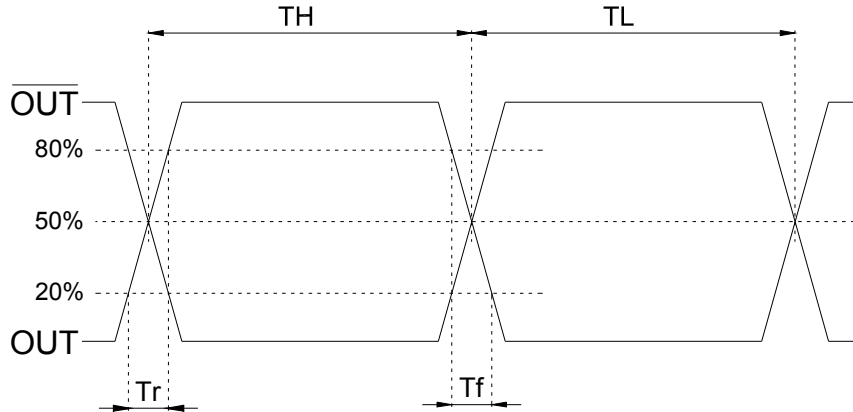

DIMENSIONS

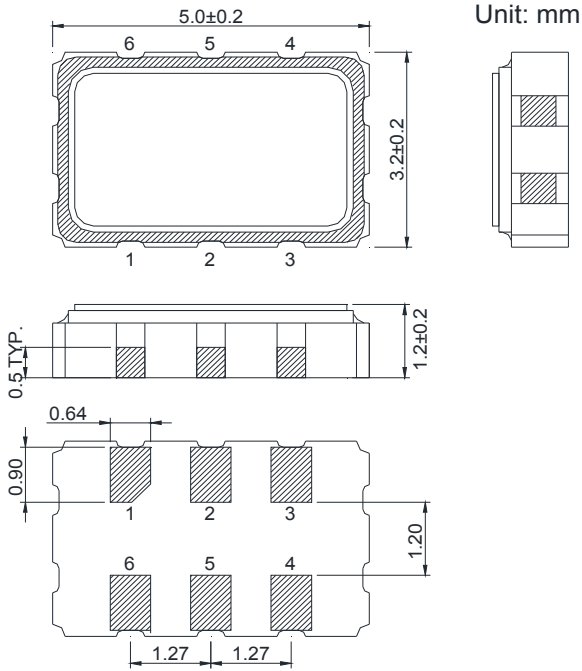

Pin Function:

- 1. OE
- 2. NC
- 3. GND
- 4. OUT
- 5. $\overline{\text{OUT}}$
- 6. VDD

Land Pattern:

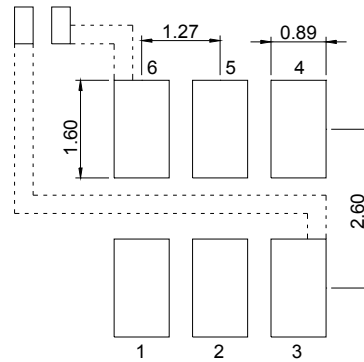

※ Pad dimension tolerance ± 0.2 mm

※ Power Supply Decoupling Capacitor is Required.

SUGGESTED REFLOW PROFILE

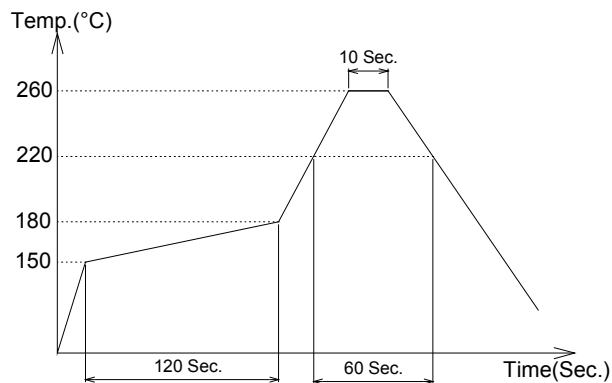

Note 1: Period while temperature exceeds the solder melting point : 220C should be less than 200 sec.

Note 2: Period while temperature stays at the top melting point : 260C should be less than 30 sec.

MARKING

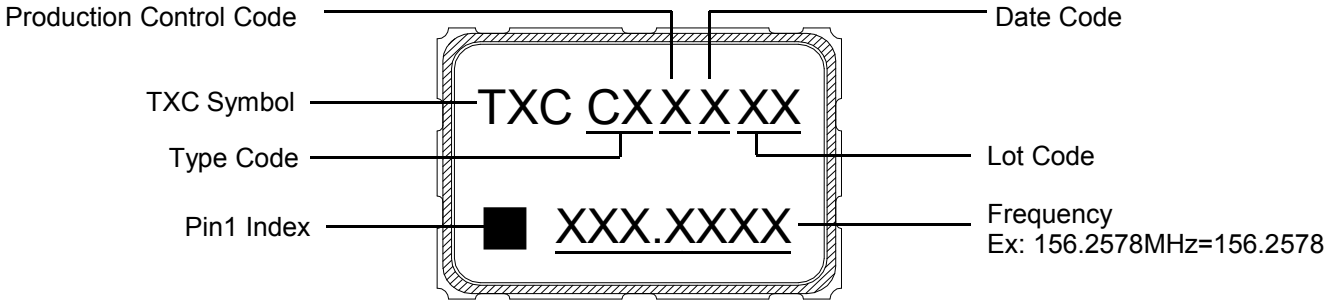

DATE CODE

MONTH YEAR					JAN	FEB	MAR	APR	MAY	JUN	JUL	AUG	SEP	OCT	NOV	DEC
					2005	2009	2013	2017	2021	A	B	C	D	E	F	G
2006	2010	2014	2018	2022	N	P	Q	R	S	T	U	V	W	X	Y	Z
2007	2011	2015	2019	2023	a	b	c	d	e	f	g	h	j	k	l	m
2008	2012	2016	2020	2024	n	p	q	r	s	t	u	v	w	x	y	z

* This date code will be cycled every four years.

TYPE CODE

Oscillation mode	Fundamental	3rd Overtone	PLL
Code	CA	CB	CC

PACKING : (EIA-481-2)

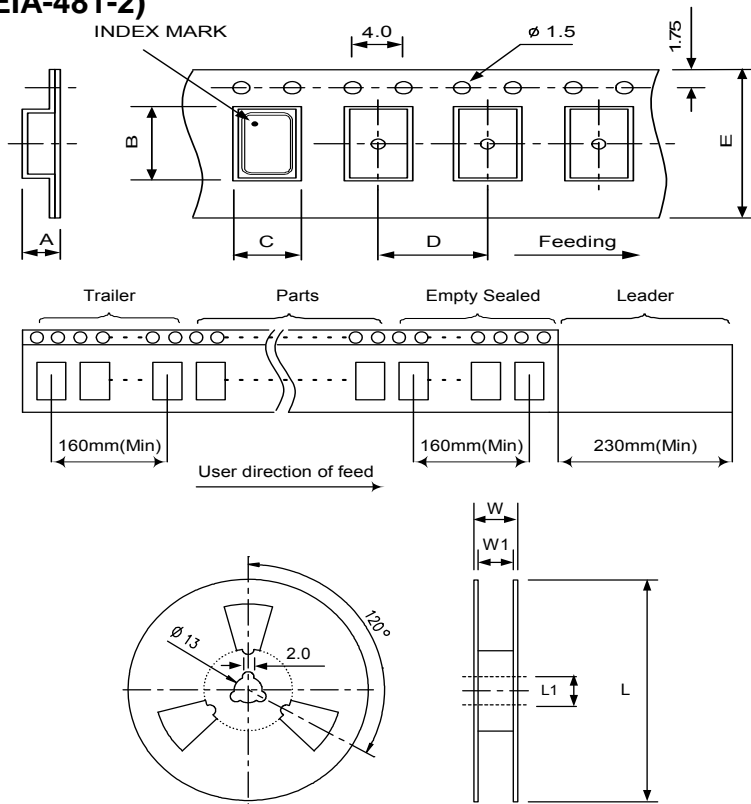

Unit: mm

DIMENSIONS	A	B	C	D	E	L	L1	W	W1	Standard Reel Quantity is 1,000 pcs per reel
	1.40	5.40	3.60	8.00	12.0	180.0	13.0	16.5	12.0	

WEIGHT

0.058±0.001 g/pcs

■ STRUCTURE ILLUSTRATION

Crystal Enclosure Seal: Seam Welding
 Crystal Enclosure Medium: Nitrogen

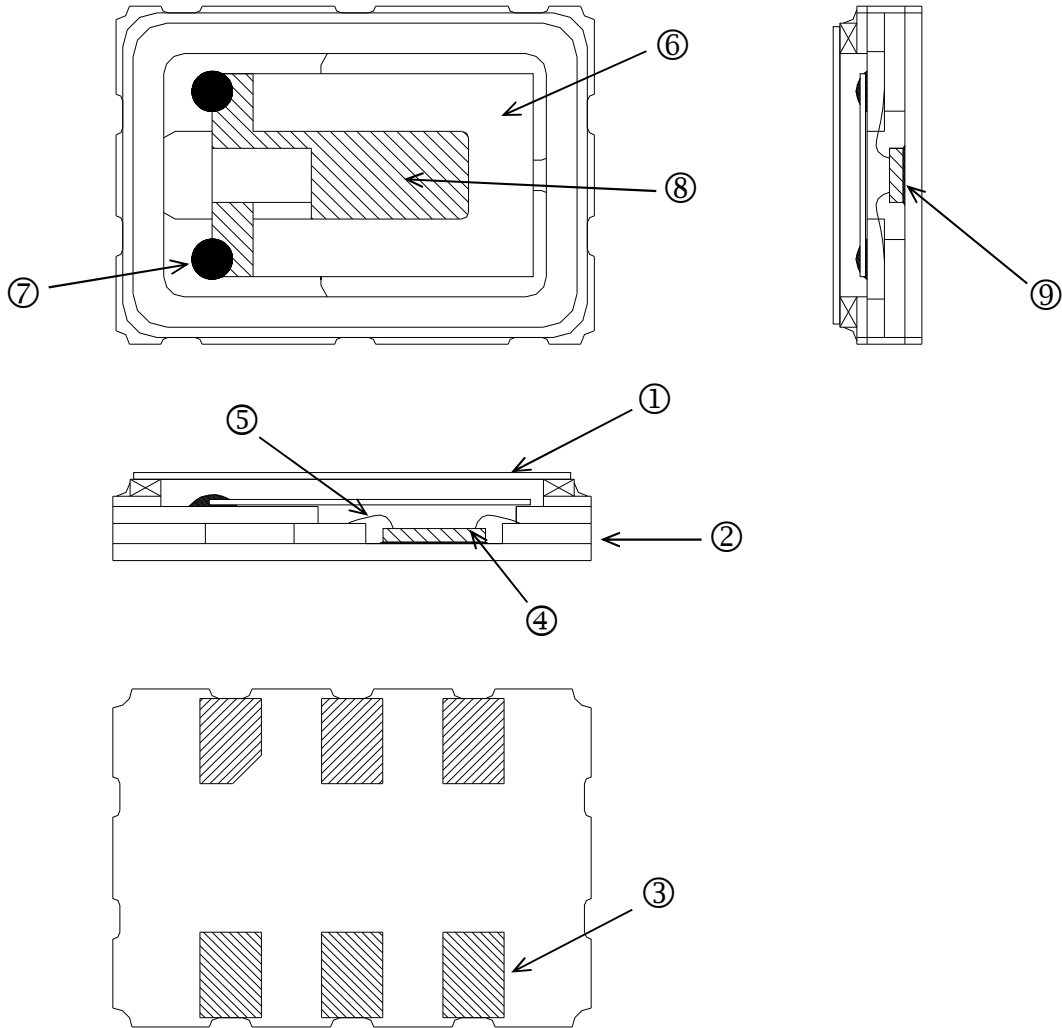

No.	COMPONENTS	MATERIALS	FINISH/SPECIFICATIONS
1	Lid	Kovar(Fe-Ni-Co)	-
2	Base(Package)	Ceramic (Al ₂ O ₃)	-
3	Pad	Au	Tungsten Metalize + Ni Plating + Au Plating
4	IC Chip	Si	-
5	Bonding Wire	Au	-
6	Crystal Blank	SiO ₂	-
7	Conductive Adhesive	Ag	Silicon Resin
8	Electrode	Au + Cr	-
9	Conductive Adhesive	Ag	Epoxy Resin

RELIABILITY SPECIFICATIONS

1. Mechanical Endurance

No.	Test Item	Test Methods	REF. DOC
1.1	Drop Test	75 cm height, fall freely onto concrete floor 3 times.	JIS C6701
1.2	Mechanical Shock	Device are shocked to half sine wave (1000 G) three mutually perpendicular axes each 3 times. 0.5m sec. duration time.	MIL-STD-202F
1.3	Vibration	Frequency range 10 ~ 2000 Hz Amplitude 1.52 mm Sweep time 20 minutes Perpendicular axes each test 4 hours (Total test time 12 hrs)	MIL-STD-883E
1.4	Gross Leak	Standard Sample For Automatic Gross Leak Detector. Test Pressure: 2Kg / cm ²	MIL-STD-883E
1.5	Fine Leak	Pre-condition - Helium Bomgng 4.5 Kgf / cm ² for 2 hrs Tested by mass-spectrometer	MIL-STD-883E
1.6	Solderability	Temperature 245 °C ± 5°C Immersing depth 0.5 mm minimum Immersion time 5 ± 1 seconds Flux Rosin resin methyl alcohol solvent (1 : 4)	MIL-STD-883E

2. Environmental Endurance

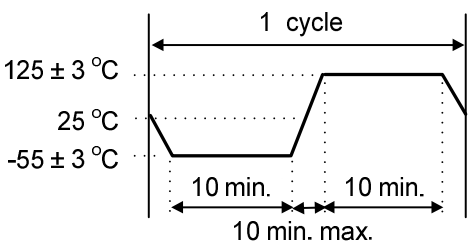
No.	Test Item	Test Methods	REF. DOC
2.1	Resistance to Soldering Heat	Pre-heat temperature 125 °C Pre-heat time 60 ~ 120 sec. Test temperature 260 ± 5 °C Test time 10 ± 1 sec.	MIL-STD-202F
2.2	High Temp. Storage	+125 °C ± 3 °C for 1000 hours	MIL-STD-883E
2.3	Low Temp. Storage	-40 °C ± 3 °C for 1000 hours	
2.4	Thermal Shock (Air to Air)	Total 100 cycles of the following temperature cycle 	MIL-STD-883E
2.5	Pressure Cooker Test	120°C ± 3°C, RH100%, 2 bar, for 240 hours	EIA-JESD22
2.6	High Temp.& Humidity	85°C ± 3°C, RH 85% , 1000 hours	EIA-JESD22
2.7	Aging	85°C ± 3°C, Voltage input by specification, 1000 hours	EIA-JESD22