

Accton Technology Corp.

## PRELIMINARY SPECIFICATION

ITEM: CRYSTAL RESONATOR

---

DSX211S

---

96.000MHz

---

---

**DAISHINKU CORP.**

1389 Shinzaike, Hiraoka-cho,  
Kakogawa, Hyogo 675-0194 Japan  
Phone(81)794-25-3141 Fax(81)794-25-1134  
[http://www.kds.info/index\\_en.htm](http://www.kds.info/index_en.htm)

C.ENG. *M. Nakajima*ENG. *M. Nagaiishi*

## 1. ELECTRICAL CHARACTERISTICS

(This test shall be performed under the conditions of temp.at +25 ± 3°C, Relative Humidity 60% max.)

(1) NOMINAL FREQUENCY	96.000000 MHz
(2) OVERTONE ORDER	Fundamental
(3) LOAD CAPACITANCE(CL)	8.0 pF
(4) FREQUENCY TOLERANCE	±12 ppm max. (at +25 ± 3 °C)
(5) DRIVE LEVEL	0.01 ~ 400 μW
(6) SERIES RESISTANCE	20 Ω max. (at Series)
(7) OPERATING TEMPERATURE RANGE	-40 ~ +105 °C
(8) FREQUENCY CHARACTERISTICS OVER TEMPERATURE (Including Aging 5 years ref. +25 deg.C, Frequency Perturbation)	±16 ppm max. / -40 ~ +105 °C (ref. to +25°C)
(9) SHUNT CAPACITANCE	2.0pF max.
(10) INSULATION RESISTANCE	500MΩ min. / DC 100 ± 15V
(11) STORAGE TEMPERATURE RANGE	-40 ~ +105 °C
(12) .SPURIOUS MODE SERIES RESISTANCE	1100 Ω min. (F0±700kHz)

## 2. CONSTRUCTION

(1) DIMENSIONS AND MARKING Refer to 4.

## 3. OTHER SPECIFICATIONS

(1) EMBOSS CARRIER TAPE & REEL Refer to 5.  
(2) PACKING Refer to 6.  
(3) REFLOW CONDITIONS (REFERENCE) Refer to 7.  
(4) LAND PATTERN (REFERENCE) Refer to 8.  
(5) OTHER HANDLING INSTRUCTIONS Refer to 9.

TITLE DSX211S TYPE QUARTZ CRYSTAL SPECIFICATION	REMARK		
DATE  2018/05/24	SPEC. No. 1ZZXAE96000BB0A	REV.	PAGE  1 / 8

4. DIMENSIONS AND MARKING

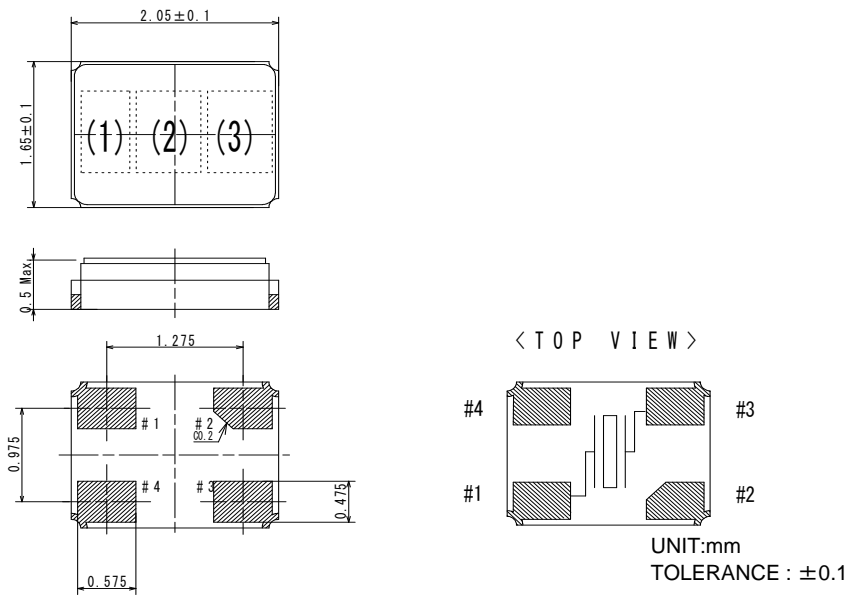

Figure-1

Logo(1) and Nominal Frequency (2) and Manufacturing lot No.( 3 )

Logo(1) = " D "

Nominal Frequency ( 2 ) = Mark two digits from upper decimal point  
(ex. 96.000000 MHz ----> 96 )

Manufacturing lot No.( 3 )

Year : The last digit of the year

week : We gave the sequence of week numbers 01(first week) for production date.

there are starting from 1st of Jan. However, add '0' figure to the first week during the nine weeks.

The week means are from Sunday to Saturday.

(ex. 2018/5/24 ---> 821 )

TITLE DSX211S TYPE QUARTZ CRYSTAL SPECIFICATION		REMARK	
DATE  2018/05/24	SPEC. No. 1ZZXAE96000BB0A	REV.	PAGE  2 / 8

5. EMOSS CARRIER TAPE & REEL

(1) Dimensions of embossed carrier tape

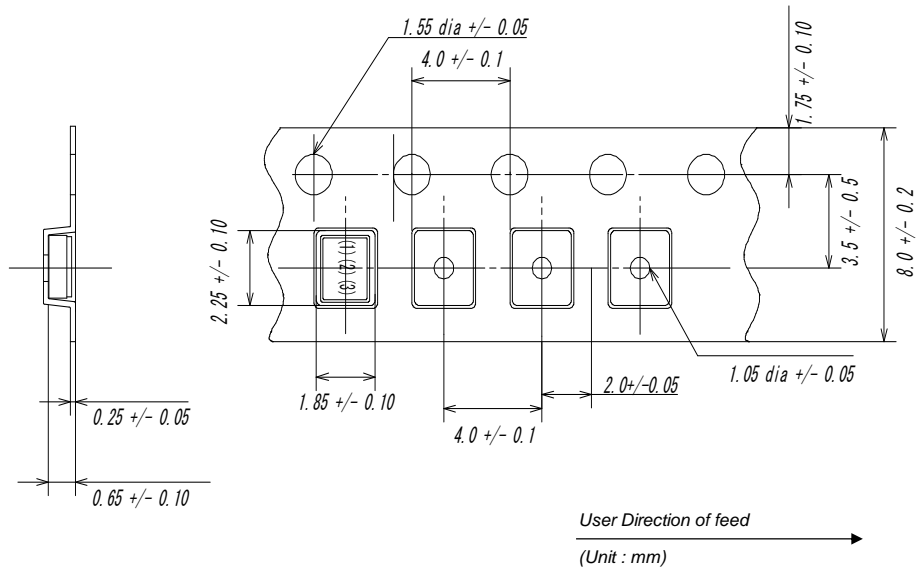

Figure-2

(2) Dimensions of tape reel

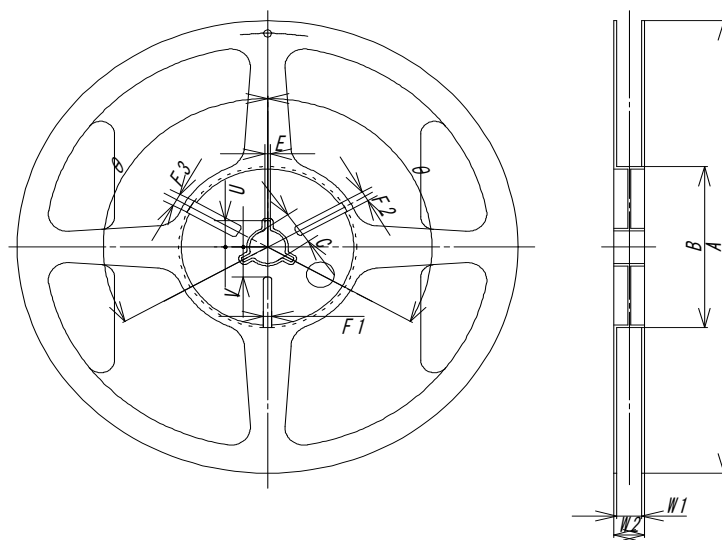

Figure-3

TITLE DSX211S TYPE QUARTZ CRYSTAL SPECIFICATION		REMARK	
DATE  2018/05/24	SPEC. No. 1ZZXAE96000BB0A	REV.	PAGE 3 / 8

(Unit:mm)

Item		Mark	Dimensions	Angle	
Flange	Diameter	A	$\Phi 180$	$+0.0 / -3.0$	
	Inside of Frange	W1		$9.0 \pm 0.3$	
	Outside of Frange	W2		$11.4 \pm 1.0$	
	Inside Diameter	B	$\Phi 60$	$+1.0 / -0.0$	
Center Core	Center Core Slit	Width	F1	$3.0 \pm 0.2$	
			F2	$4.0 \pm 0.2$	
			F3	$5.0 \pm 0.2$	
	Center Core Slit	Length	V		$11.9 +0.5 / -0.0$
		Angle	$\theta$		$120^\circ$
	Spindle Diameter		C		$\Phi 13 \pm 0.2$
	Key Seats	Width	E		$2.0 \pm 0.5$
		Length	U		$10.5 \pm 0.4$
		Angle	$\theta$		$120^\circ$

## (3) Storage condition

Temperature :  $+40^\circ\text{C}$  max.

Relative Humidity : 80% max.

( It is a guaranteed term because it obtains an excellent soldering: 6 months)

## (4) Standard packing quantity

3,000 pcs/reel

## (5) Material of the tape

Tape	Material
Carrier tape	Polystyrene+Carbon
Cover tape	Polyester

TITLE DSX211S TYPE QUARTZ CRYSTAL SPECIFICATION		REMARK	
DATE  2018/05/24	SPEC. No. 1ZZXAE96000BB0A	REV.	PAGE 4 / 8

(6) Label contents

- Type
- Our specification No.
- Your Part No.
- Lot No.
- Nominal Frequency
- Quantity
- Our Company Name
- Producing Country

Stick a label on the each reel.

(7) Taping dimension

Leader	Cover-tape	The length of cover-tape in the leader is more than 400mm including empty embossed area.
	Carrier-tape	After all products were packaged, must remain more than twenty pieces or 400mm empty area, which should be sealed by cover-tape.
Trailer	Cover-tape	The empty embossed area which are sealed by cover-tape must remain more than 40mm.
	Carrier-tape	

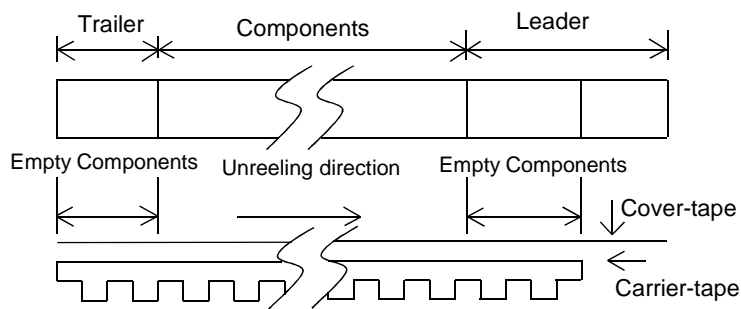

Figure-4

(8) Joint of tape

The carrier-tape and cover-tape should not be jointed.

(9) Release strength of cover tape

It has to between 0.1 ~ 0.7N under following condition.

Pulling direction 165 ~ 180 °

Speed 300mm/min

Otherwise unless specified.

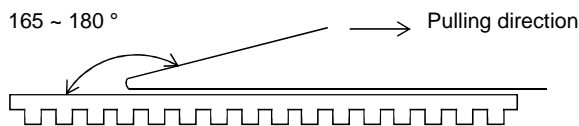

Figure-5

Other standards shall be based on JIS C 0806 -1990-

TITLE DSX211S TYPE QUARTZ CRYSTAL SPECIFICATION		REMARK	
DATE  2018/05/24	SPEC. No. 1ZZXAE96000BB0A	REV.	PAGE 5 / 8

6. PACKING

(1) STORAGE METHOD

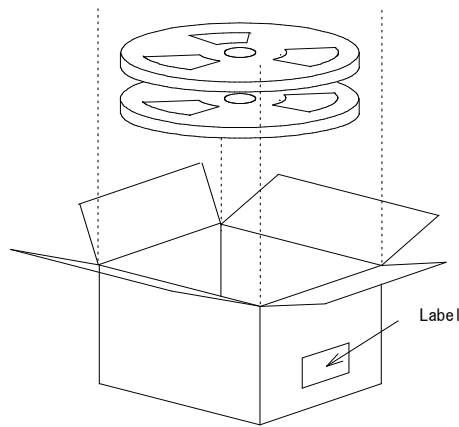

Label contents

- The type of product
- Lot No.
- Specification
- Quantity
- Shipment Day
- Remark

Figure-6

(2) BOX SIZE

From lot size packingsize shall be changed.

In the upper and lower part and the opening in box it shall be protected products using aircushion sheets.

TITLE DSX211S TYPE QUARTZ CRYSTAL SPECIFICATION		REMARK	
DATE  2018/05/24	SPEC. No. 1ZZXAE96000BB0A	REV.	PAGE  6 / 8

7. REFLOW CONDITIONS (REFERENCE)

During the solder reflow process, please complete within following temperature, period.  
 Reflow soldering shall be allowed only 2 times.

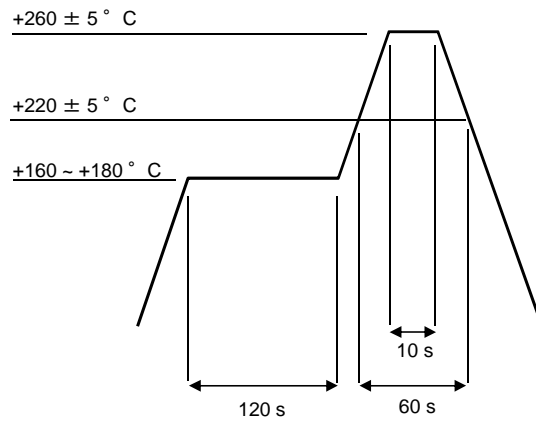
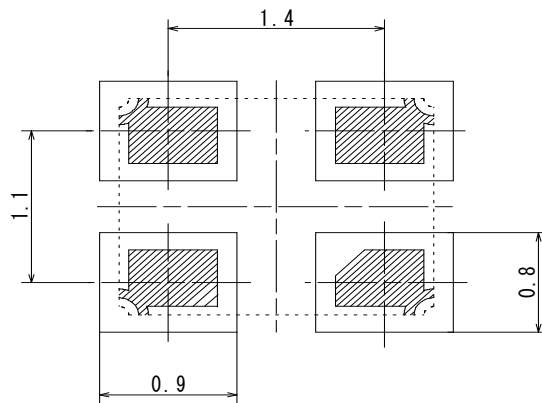

Figure-7

HANDSOLDERING METHOD : +350 ± 10 °C , 3+1/-0s Each terminal once  
 (Please take care so that a soldering iron should not touch a product directly.)

8. LAND PATTERN (REFERENCE)



Unit : mm

Figure-8

TITLE DSX211S TYPE QUARTZ CRYSTAL SPECIFICATION		REMARK	
DATE  2018/05/24	SPEC. No. 1ZZXAE96000BB0A	REV.	PAGE 7 / 8



## 9. DSX211S TYPE QUARTZ CRYSTAL HANDLING INSTRUCTIONS

## (1) SOLDERING

Please perform the attached Reflow conditions to reference within 2 times.

## (2) MOUNT

Crystal products are designed to be compatible with automatic mounting.

Be sure to have a mounting test in advance by using the actual mounting machine and check that the characteristics of the products are not damaged by the automatic mounting.

In the process where the board is warped, such as board separation process, be careful that the warping does not influence the characteristics and soldering of crystal products.

Since mounting by Ultrasonic welding and processing have a possibility of an excessive vibration spreading inside a crystal resonator and becoming the cause of characteristic deterioration and not oscillating, it does not recommend.

## (3) WASHING

About use of the washing liquid of a basin system, an alcoholic system, and a chlorofluorocarbon-replacing material system, it is checking that it is satisfactory.

However please consult in advance about other washing liquid.

Although the check about ultrasonic washing is performed, since it is an examination with a simple substance, the check for the second time by the use state is recommended.

## (4) THE CAUTIONS ON USE

The piece of crystal it is processed very smaller than the conventional thing inside DSX211S series crystal unit may be damaged, if excessive excitation electric power is applied.

Please use it below with the value specified on a catalog and specifications.

Please refrain from forming patterns between crystal land pattern's since there is a possibility to cause crack in base.

If the temperature is higher than +280 °C, there is a possibility for the sealing alloy to remelt.

Avoid using the product at temperature higher than specified.

## (5) HANDLING OF A PRODUCT

DSX211S series has sufficient intensity to fall and vibration.

However when too much shock is added according to a certain cause, the use after a characteristic check is recommended.

## (6) STORAGE

Since the soldering nature of a terminal may be degraded, please avoid storage in high temperature and a humid place.

Please keep it in the place which direct rays do not hit and dew condensation does not generate.

TITLE DSX211S TYPE QUARTZ CRYSTAL SPECIFICATION	REMARK		
DATE  2018/05/24	SPEC. No. 1ZZXAE96000BB0A	REV.	PAGE  8 / 8