



# Temperature Sensing

## 2Z-Series

### ■ Features

- 2.5 x 2.0 x H0.9 mm

### ■ Applications

- Digital Electronics, Consumer Products
- Mobile Communications
- Bluetooth, Wireless LAN



### ■ General Specifications

#	Items	Parameters
1	Frequency range	19.2MHz, 26MHz, 38.4MHz, 52MHz, 76.8MHz
2	Load capacitance (CL)	7.0pF, 8.0pF, 9.0pF
3	Operating temperature	- 30 to +105°C
4	Storage temperature	- 40 to +105°C
5	Initial frequency tolerance	±10ppm, - 10 ~+22ppm
6	Frequency tolerance over temperature	±12ppm@- 30 to +85°C, ±30ppm@- 40 to +105°C
7	Frequency aging	±0.7ppm/year
8	Equivalent series resistance	80Ω
9	First-order curve fitting parameter	-0.4~-0.1 (ppm/°C)
10	Second-order curve fitting parameter	±4.5/±6 (ppm/°C)
11	Third-order curve fitting parameter	+8.5~+11.5 ( x10 <sup>-5</sup> ppm/°C <sup>3</sup> )
12	Thermistor resistance	100kΩ (At 25°C)
13	Thermistor B-constant	4,250K

### ■ Package Dimensions, Pad Functions, & Recommended Land Pattern (Unit: mm)

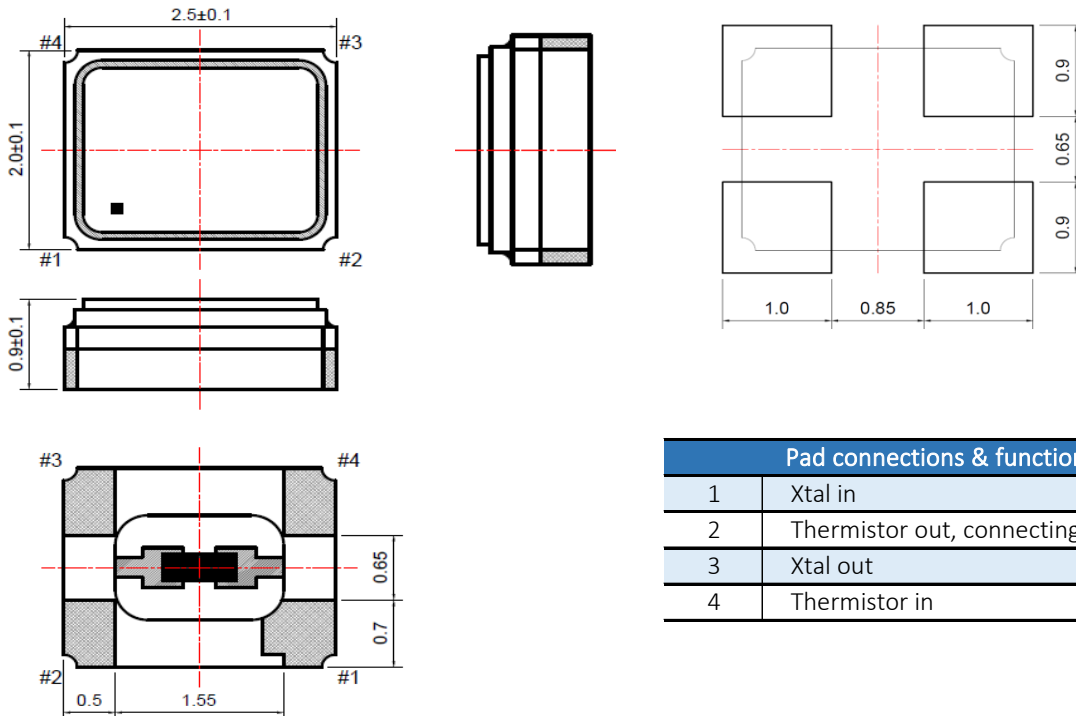

Pad connections & functions	
1	Xtal in
2	Thermistor out, connecting to ground
3	Xtal out
4	Thermistor in

Visit website

