



Features

- 4-Pin Dip
- Fast warm-up
- TCXO replacement for better short term stability
- Frequency Range, 10 MHz to 40 MHz
- Standard frequencies, 10,19.44,20,24.576,25,26,38.88, 40 MHz);

Applications

- Base stations
- Test equipment
- Synthesizers
- Military communication equipment

Performance Specifications

Frequency Stabilities ¹ (10 to 40 MHz)					
Parameter	Min	Typical	Max	Units	Condition
vs. operating temperature range (referenced to +25°C)	-5		+5	ppb	-40 to +85°C
	-10		-10	ppb	-40 to +85°C
	-10		-10	ppb	-40 to +95°C
Initial tolerance	-0.2		+0.2	ppm	at time of shipment, nominal EFC
vs. supply voltage change	-10		+10	ppb	V _s ±5% static
vs. load change	-10		+10	ppb	Load ±5% static
vs. aging / day	-1.0		+1.0	ppb	after 30 days of operation
vs. aging / year	-100		+100	ppb	after 30 days of operation
vs. aging / 10 years	-1000		+1000	ppb	after 30 days of operation
hold over					
start up time					
Warm-up time			3	minutes	to ±100ppb of final frequency (1 hour reading) @ +25°C

Performance Specifications

Supply Voltage (Vs)					
Parameter	Min	Typical	Max	Units	Condition
Supply voltage (standard)	3.135	3.3	3.465	VDC	
	4.75	5.0	5.25	VDC	
Power consumption			2.5	Watts	during warm-up
			1.0	Watts	steady state @ +25°C
RF Output					
Signal [standard]	HCMOS				
Load		15		pF	
Signal Level (Vol)			0.4	VDC	with Vs=3.3V and 15pF Load
Signal Level (Vol)			0.5		with Vs=5.0V and 15pF Load
Signal Level (Voh)	2.4			VDC	with Vs=3.3V and 15pF Load
Signal Level (Voh)	3.5				with Vs=5.0V and 15pF Load
rise time			5	ns	
fall time			5	ns	
Duty Cycle	45		55	%	@ (Voh-Vol)/2
Frequency Tuning (EFC)					
Tuning Range	Fixed OCXO; No adjust				Opti- on ^s
	±1.0		±3	ppm	
Linearity	10%				
Tuning Slope	Positive				
Control Voltage Range	0.0	1.4	2.8	VDC	with Vs=3.3V
	0.0	2	4.0	VDC	with Vs=5.0V
Additional Parameters					
Phase Noise ³		-85 -121 -140 -152 -155		dBc/Hz dBc/Hz dBc/Hz dBc/Hz dBc/Hz	1 Hz 10 Hz 100 Hz 1 kHz 10 kHz
Weight			8.0	g	@ 20MHz
Processing & Packing	Handling & Processing Note				
Absolute Maximum Ratings					
supply voltage (Vs)			5.5	V	with Vs=3.3 & 5.0 VDC
Output Load			50	pF	
Operable Temperature Range	-45		+85	°C	
Storage Temperature Range	-45		+85	°C	

Outline Drawing / Enclosure

G 125

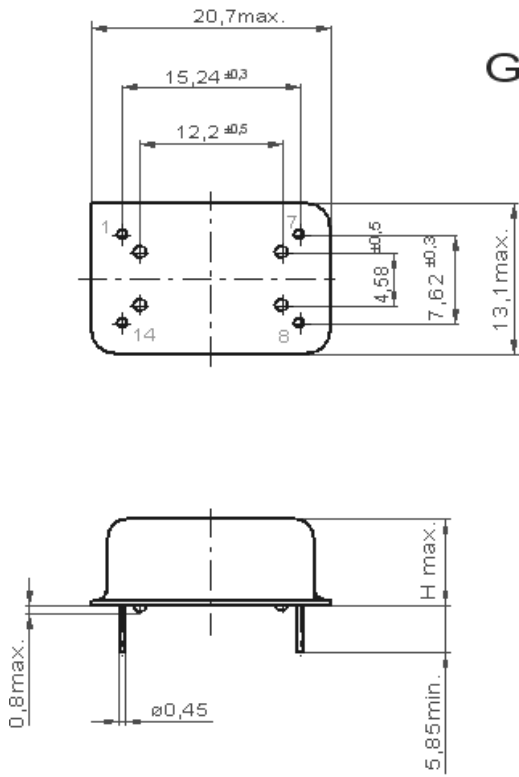

OX-400	
Height "H"	Pin Length "L"
8.5	5.85min.

Pin Connections	
1	Electronic Frequency Control Input (EFC)
7	Ground (Case)
8	RF Output
14	Supply Voltage Input

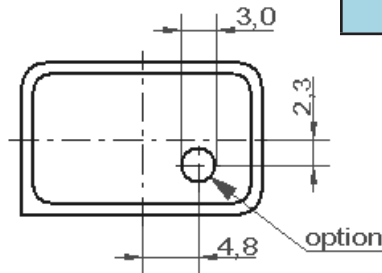

G 269

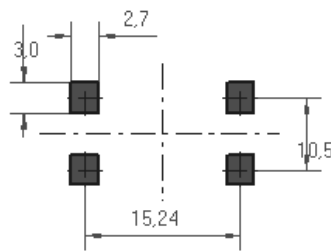
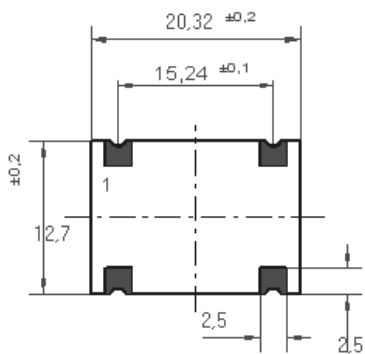
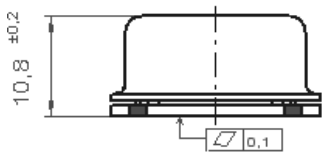
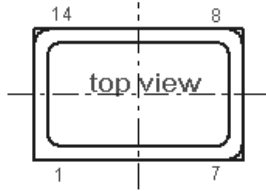

Padvorschlag
PCB Layout

OX-401	
Height "H"	Pin Length "L"
10.8	N/A

Pin Connections	
1	Electronic Frequency Control Input (EFC)
7	Ground (Case)
8	RF Output
14	Supply Voltage Input

Dimensions in inches mm

Standard Shipping Method (OX-401)

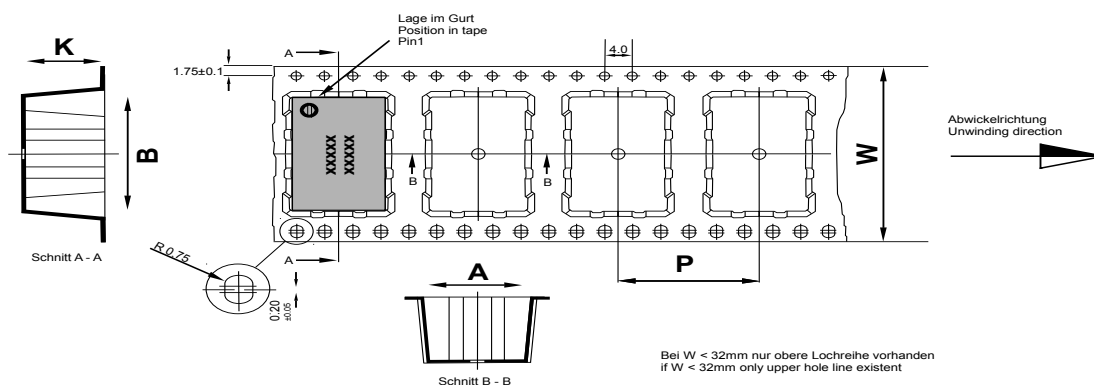

Maßangaben in mm: A, B und K Maße von Bauelement abhängig Fertigungstoleranzen entsprechen der DIN IEC 286-3	Dimension in mm: A, B und K are dependent upon component dimensions production tolerance complying DIN IEC 286-3
--	--

All dimensions in millimeters unless otherwise stated

Enclosure Type	Tape Width W (mm)	Quantity per meter	Quantity per reel	Dimension P
Typ OX-401	32	50	250	20

Standard Shipping Method (OX-400)

Enclosure Type	Method	colloums	rows	Quantity per Tray
Typ OX-400	Tray	10	8	80

Recommended Reflow Profile

IPC/JEDEC J-STD-020 (latest revision)

Additional Information:

This SMD oscillator has been designed for pick and place reflow soldering.

SMD oscillators must be on the top side of the PCB during the reflow process.

Additional Environmental Conditions

Parameter	Description
Rapid temperature changes	MIL-883-1010 Cond B 1000 cycles -55/125C
Vibration	MIL-STD-883 Meth 2007 Cond A 20G 20-2000Hz 4x in each 3axis 4 min
Shock	JESD22-B104-B 100G 1,5ms 6 shocks in each direction
Solderability	J_STD_002C Cond A, Through hole device/ Cond. B, SMD 255C (diving time 50,5sec.) Dip+Look with 8h damp pre-treatment: solder wetting >95%
Solvent resistance	MIL-STD-883 Meth 2015 Solv. 1,3,4
ESD	HBM JESD22-A114-E Class 2 10* 2000V
Moisture Sensit.	Level 1 JESD22-A113-B
RoHS compliance	100% RoHS 6 compliant
Washable	washable device

typical performance data

typical warm up

@ OX-400-EAE-1080-20M000

typical temp stability

@ OX-400-EAE-1080-20M000

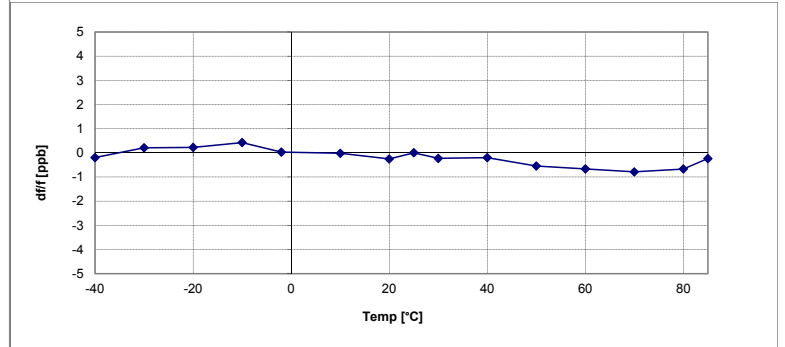
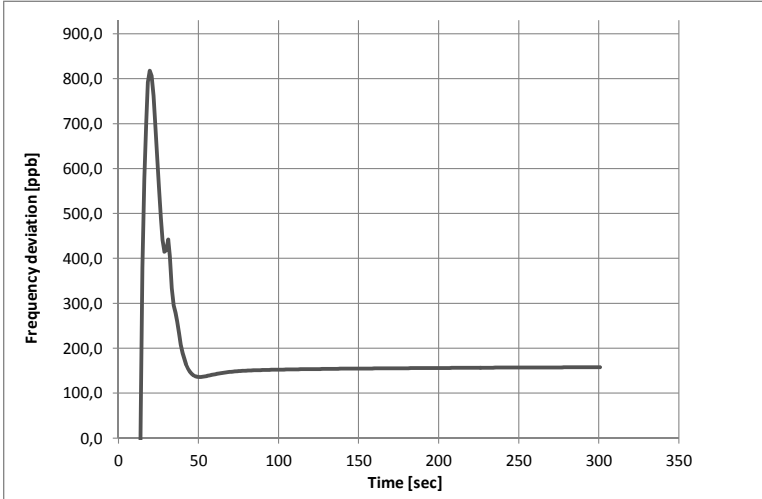

typical Phase Noise

@ OX-400-EAE-1080-20M000

@ OX-400-EAE-1080-20M000

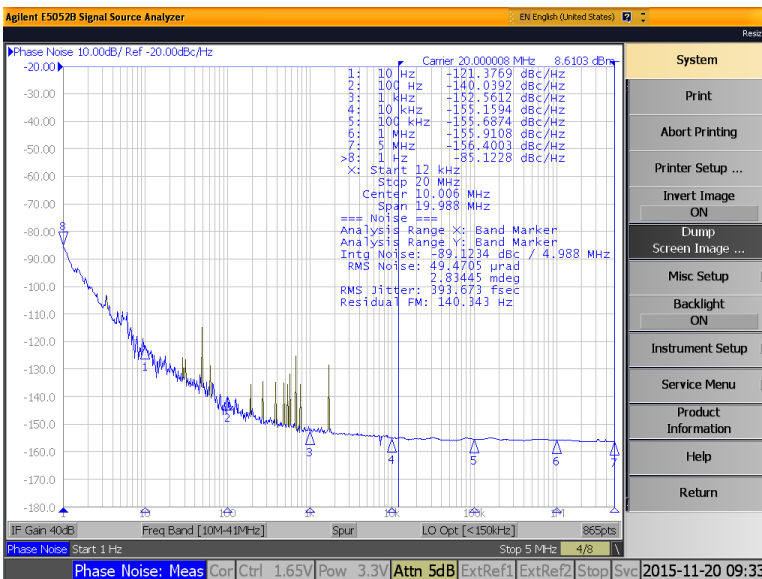

typical performance data

typical aging data

@ OX-400-EAE-1080-20M000

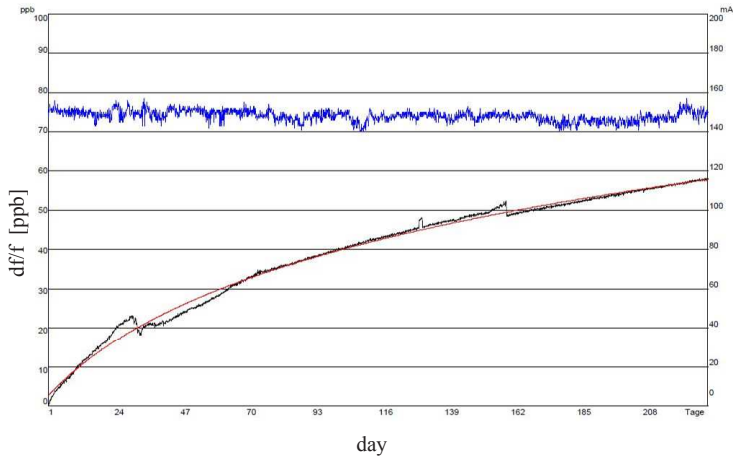

typical frequency vs. supply voltage

@ OX-400-EAE-1080-20M000

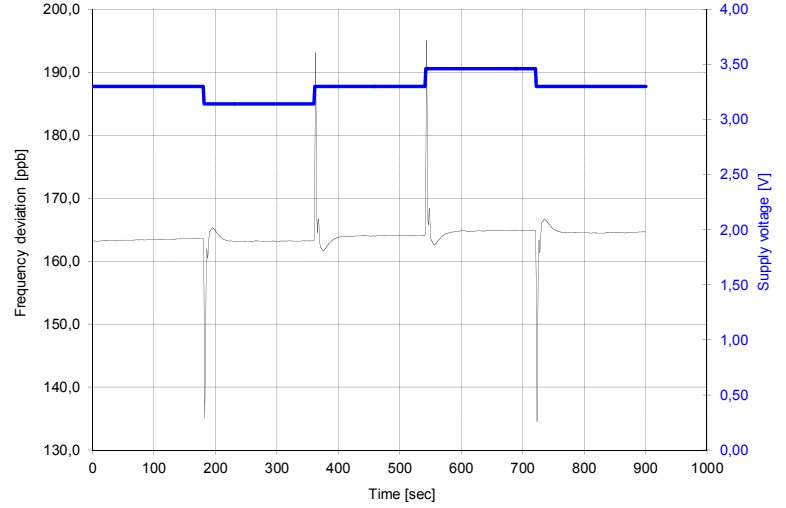

typical ADEV

@ OX-400-EAE-1080-20M000

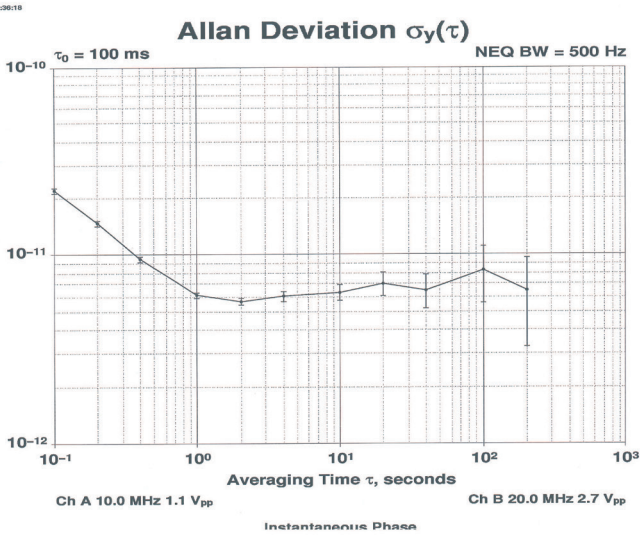

typical retrace

@ OX-400-EAE-1080-20M000

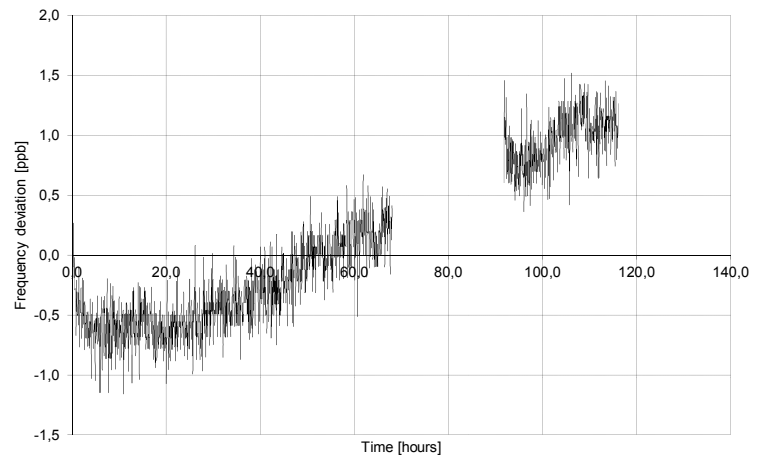

typical performance data

typical case temperature vs outside temperature

@ OX-400-EAE-1080-20M000

typical power consumption vs operating temperature

@ OX-400-EAE-1080-20M000

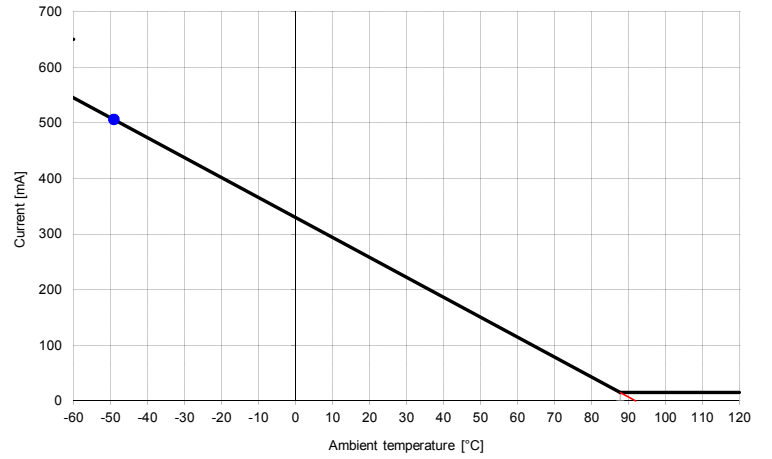
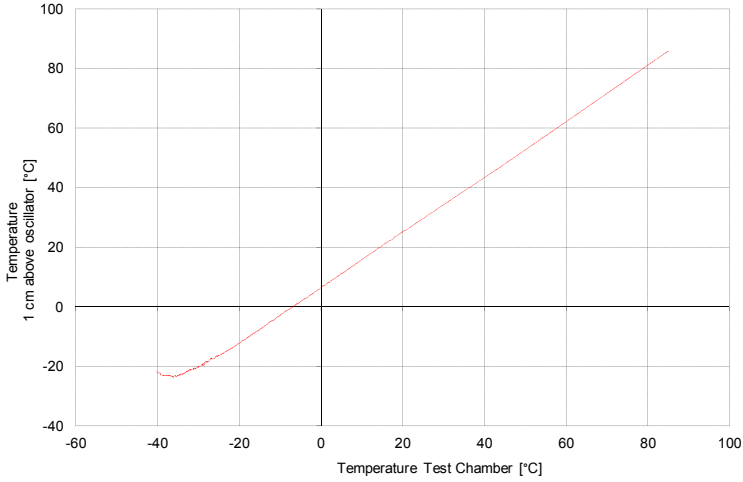

recomended power on time after x days of power off

@ OX-400-EAE-1080-20M000



Ordering Information

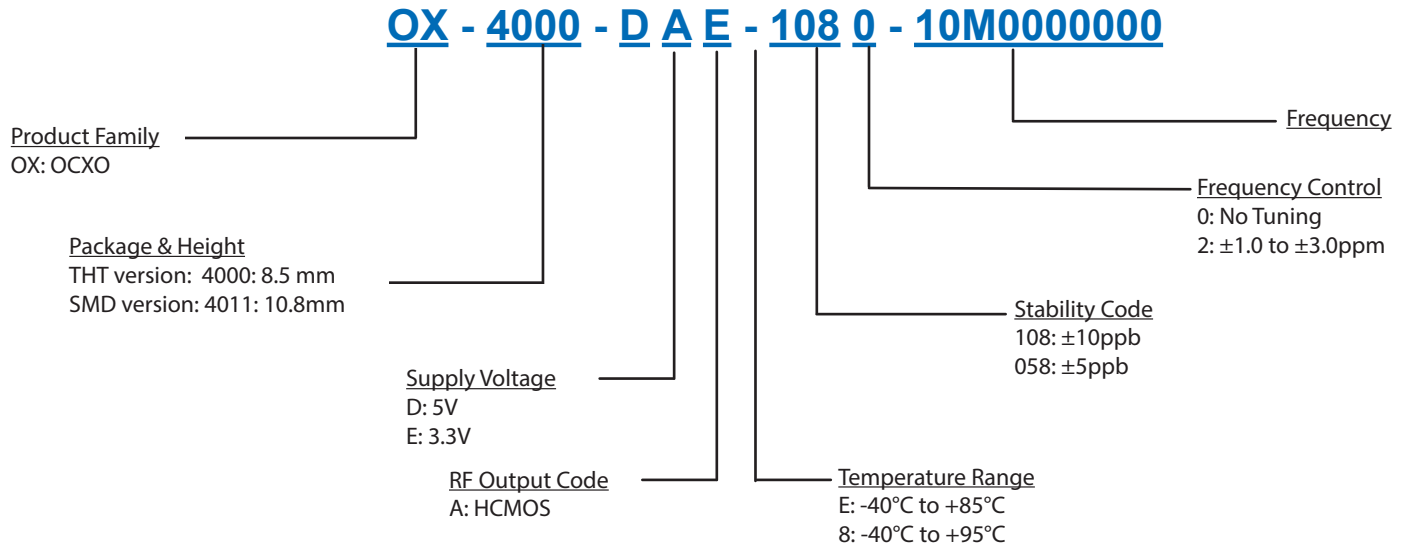

Notes:

1. Contact factory for improved stabilities or additional product options. Not all options and codes are available at all frequencies.
2. Unless other stated all values are valid after warm-up time and refer to typical conditions for supply voltage, frequency control voltage, load, temperature (25°C).
3. Phase noise degrades with increasing output frequency.
4. Subject to technical modification.
5. Contact factory for availability.

Contact Information

USA:

100 Watts Street
Mt Holly Springs, PA 17065
Tel: 1.717.486.3411
Fax: 1.717.486.5920

Europe:

Landstrasse
74924 Neckarbischofsheim
Germany
Tel: +49 (0) 7268.801.0
Fax: +49 (0) 7268.801.281



Information contained in this publication regarding device applications and the like is provided only for your convenience and may be superseded by updates. It is your responsibility to ensure that your application meets with your specifications. MICROCHIP MAKES NO REPRESENTATION OR WARRANTIES OF ANY KIND WHETHER EXPRESS OR IMPLIED, WRITTEN OR ORAL, STATUTORY OR OTHERWISE, RELATED TO THE INFORMATION INCLUDING, BUT NOT LIMITED TO ITS CONDITION, QUALITY, PERFORMANCE, MERCHANTABILITY OR FITNESS FOR PURPOSE. Microchip disclaims all liability arising from this information and its use. Use of Microchip devices in life support and/or safety applications is entirely at the buyer's risk, and the buyer agrees to defend, indemnify and hold harmless Microchip from any and all damages, claims, suits, or expenses resulting from such use. No licenses are conveyed, implicitly, or otherwise, under any Microchip intellectual property rights unless otherwise stated.

Trademarks

The Microchip and Vectron names and logos are registered trademarks of Microchip Technology Incorporated in the U.S.A. and other countries.